

Model year 2011 SUN ODYSSEY

Sun Odyssey 409



Sun Odyssey 42i



Sun Odyssey 42i Performance

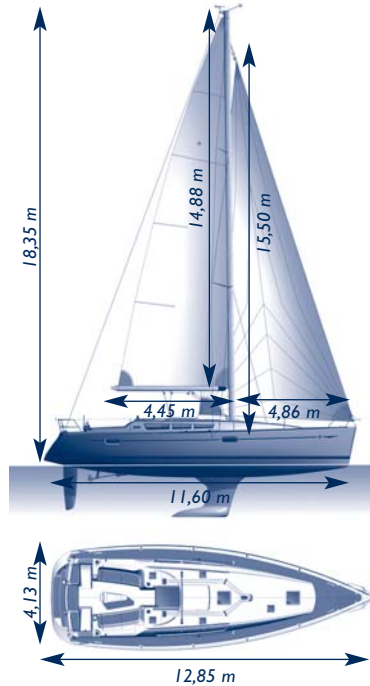
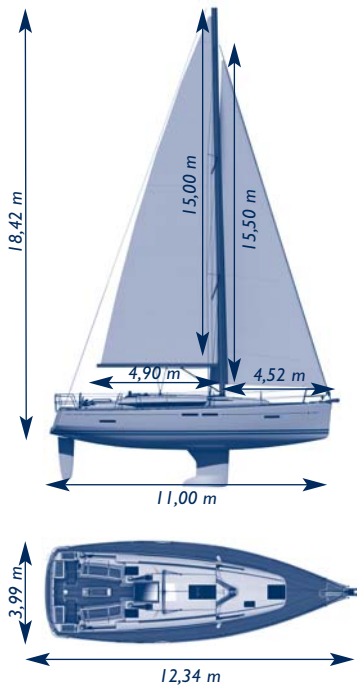

Certification conform with CE regulation.

	SO 409	SO 42i	SO 42i Performance
Overall length	12,34 m	12,85 m	12,85 m
Hull length	11,98 m	12,59 m	12,59 m
Waterline length	11,00 m	11,60 m	11,60 m
Beam	3,99 m	4,13 m	4,13 m
Displacement <i>light load with deep draft keel</i>	7450 kg	8410 kg	8410 kg
Standard draft <i>cast iron fin keel with elongated bulb and exterior epoxy barrier coat</i>	2,10 m	2,13 m	2,13 m
Standard keel weight	2260 kg	2553 kg	2553 kg
Shoal draft <i>cast iron fin keel with elongated bulb and exterior epoxy barrier coat</i>	1,55 m	1,60 m	-
Shoal keel weight	2470 kg	2781 kg	-
Performance keel draft <i>cast iron fin keel with elongated bulb and exterior epoxy barrier coat, profiled leading and trailing edges</i>	-	-	2,30m
Performance keel weight	-	-	2520 kg
CE category (* in process)	A8*	A9/B10/C14	A9/B10/C14
Architect/designer	P. Briand	M. Lombard	M. Lombard
Water <i>2 rotomolded tanks located under forward and aft berths with separate deck fills</i>	330 L + 200 L	355 L	355 L
Fuel <i>rotomolded tank located under aft berth with deck fill</i>	200 L	130 L	130 L
Holding tank <i>rotomolded tank located in head compartment with valve for overboard discharge via gravity and deck fitting for pump out</i>	80 L	85 L	85 L
Fridge <i>fridge compartment with vertical access</i>	180 L	180 L	180 L

Classic mainsail <i>high-tenacity Dacron cloth, Rutgerson® stainless steel eyes, 2 auto reefs</i>	42 m ²	39,1 m ²	-
Furling jib <i>106% high-tenacity Dacron cloth, Sunbrella® UV luff protection, Rutgerson® stainless steel eyes</i>	35 m ²	-	-
Self-tacking jib <i>high-tenacity Dacron cloth, Sunbrella® UV luff protection, Rutgerson® stainless steel eyes, option includes track on deck</i>	28 m ²	-	-
Furling genoa <i>122% high-tenacity Dacron cloth, Sunbrella® UV luff protection, Rutgerson® stainless steel eyes</i>	-	42,4 m ²	-
Performance Full Batten mainsail <i>Prestige series tri-radial with sandwich construction of double taffeta layers for form stability, 2 automatic reefs</i>	45 m ² X	-	42 m ²
Performance furling genoa <i>140% tri-radial Prestige series with sandwich constructions of double taffeta layers for form stability and Sunbrella® UV luff protection, Rutgerson® stainless steel eyes</i>	48 m ² X	-	-
Performance furling genoa 125% <i>tri-radial Prestige series with sandwich constructions of double taffeta layers for form stability and Sunbrella® UV luff protection, Rutgerson® stainless steel eyes</i>	-	-	47,5 m ²
Furling mainsail (optional) <i>high-tenacity Dacron cloth, Sunbrella® UV luff protection, Rutgerson® stainless steel eyes</i>	36,5 m ²	35 m ²	-
Spinnaker <i>optimal size for boat (not available from Jeanneau)</i>	120 m ²	115 m ²	135 m ²
Total sail area <i>for standard mast and sails</i>	78 m ²	81,5 m ²	89,5 m ²

X Performance plus package * Navigation package ■ Standard □ Option - Not available

This document is non contractual and we reserve the right to modify equipment or specification without advance notice. Updated July 2010.

		SO 409	SO 42i	SO 42i Performance
Sail handling	Lazy bag in Sunbrella® Taupe fabric with integrated lazy jacks	■	■	■
	Genoa winches 2 x Harken 46.2 self-tailing winches	■	■	-
	Genoa winches 2 x Harken 50.2 self-tailing winches	-	-	■
	Coachroof winch Harken 40.2 self-tailing winches to port	■	■	■
	Coachroof winch Harken 40.2 self-tailing winches to starboard	*	■	■
	Harken "Rewind" electric genoa winches 2 x 46.2 winches that can sheet-in and sheet-out electrically	□	-	-
	Electric genoa winches 2 x Harken 46.2 12v self-tailing in place of standard winches	-	□	□
	Electric coachroof winch 1 x Harken 40.2 12v self-tailing in place of standard winch to port	PREFERENCE	PREFERENCE	PREFERENCE
	Genoa tracks adjustable Harken lead cars (Located on the coachroof for the Sun Odyssey 409)	■	■	-
	Genoa tracks adjustable Harken lead cars with adjustment line lead aft to cockpit jammer (located on the side decks)	X	-	■
	Winch handles 2 x Harken handles with ball-bearing grip	■	■	■
	Mainsheet and genoa sheet lead back to helm station with Spinlock jammers	■	-	-
	Line jammers Spinlock, on both sides of coachroof with return blocks	■	■	■
	Mainsheet traveller roof-mounted traveller with ball-bearing cars, control lines lead aft to cockpit	■	■	■
	Spinnaker deck hardware double Spinlock jammer coachroof and single jammer near starboard helm	*	-	-
	Spinnaker deck hardware triple Spinlock jammer to starboard, 5 folding Wichard padeyes on side decks	-	■	■
Asymmetrical spinnaker gear halyard, 2 sheets, tack line lead forward on deck, attachment point on stemhead fitting, Harken blocks	□	-	-	
Asymmetrical spinnaker gear halyard, 2 sheets, tack line lead forward on deck, removable bowsprit on foredeck, Harken blocks	-	□	□	
Symmetrical spinnaker gear halyard, 2 sheets, 2 guys, pole uphaul and downhaul, spinnaker pole and adjustable car for mast, Harken blocks	□	□	□	
Mast and Rigging	Classic mast aluminium with double spreaders	■	■	-
	Performance mast aluminium with double spreaders	-	-	■
	Standing rigging discontinuous 1x19 stainless steel wire	■	■	-
	Standing rigging discontinuous Dyform® stainless steel wire	X	-	■
	Backstay fixed	■	■	-
	Backstay adjustable via mechanical adjuster	*	-	-
	Backstay adjustable via a block and tackle system and bridle-mounted car	-	-	■
	Genoa furler with double slot, attachment to stemhead fitting and furling line lead aft to port helm winch	■	-	-
	Genoa furler with attachment to stemhead fitting and furling line lead aft to roof winch	-	■	-
	Genoa furler racing series with removable drum, double sail slot, mounted to stemhead fitting, furling line lead aft to roof winch	-	-	■
	Running rigging polyester topping lift, mainsail halyard, genoa halyard, mainsheet, genoa sheets	■	■	-
	Running rigging Dyneema® mainsail halyard, genoa halyard, mainsheet, genoa sheets	X	-	■
Rigid boom vang with gas cylinder and control line lead aft to the cockpit	*	■	■	
Cockpit	Wood inlay on cockpit bench seating	■	■	■
	Wood cockpit floor inlay	□	□	□
	Wood side decks hand-laid wooden side decks	□	□	□
	Cockpit lockers 2 lockers under bench seats and 1 lazette locker under the port helm seat for technical access to steering system	■	■	■
	Liferaft locker located in dedicated compartment between helm seats	■	■	■
	Storage compartment for companionway door in forward section of liferaft locker	■	-	-
	Fold down swim platform with telescopic swim ladder	■	-	-
	Cockpit table folding table with storage, cup holders, stainless steel handrail, courtesy lighting, 12v plug	■	-	-
	Cockpit table folding injection-moulded fibreglass table with storage, cup holders, stainless steel handrail, courtesy lighting, 12v plug	-	■	■
	Solid wood cockpit table with all the same functions of the standard table, but with wooden leaves and top Sunbrella® Taupe cover	□	□	□
	Gas locker located in lazette locker under starboard helm seat, room for 2 gas bottles with connection to gas system and cut-off valve under stove in the galley	■	■	■
	Wheels 2 leather-covered steering wheels with compasses at each steering position and stainless steel grabrails	■	■	■
	Black, composite steering wheels	X	-	-
	Emergency tiller delivered with the boat, chrome fitting in cockpit floor	■	■	■
	Steering wheel covers Sunbrella® Taupe with zips for easy removal	□	□	□
	Instrumentation dedicated space for instruments within easy reach of helm positions, room for GPS chartplotter mounted at aft end of cockpit table with easy viewing from each helm	■	■	■
	Engine controls throttle and engine control panel mounted at starboard helm, engine panel includes, RPM gauge, warning lights, ignition	■	■	■
	Swim ladder folding stainless steel ladder mounted on transom	-	■	■
	Cockpit shower retractable hot and cold water shower with tap	PREMIERE	■	■
	Cockpit cushions Sunbrella® Taupe cushions for seating area with attachment clips	□	-	-
Cockpit bimini Sunbrella® Taupe with stainless steel bows, retractable with storage cover	□	□	-	
Cockpit sprayhood wide Sunbrella® Taupe with vinyl windscreen with zip-out middle window for ventilation, retractable	□	□	□	
Anchor locker room for anchor and tackle, integrated windlass area, holder for windlass handle	■	■	■	
Deck Hardware	Bow pulpit open, stainless steel	■	■	■
	Stern pulpits stainless steel with flag holder, buoy bracket	■	■	■
	Outdoor engine bracket mounted on stern pulpit	□	□	□
	Electric windlass Quick 1000W combination rope and chain, vertical-mounted in the anchor locker, hand-held remote, manual handle	PREMIERE	■	■
	Windlass control second windlass control mounted in cockpit with chain counter for easy, short-handed anchoring	□	-	-
	Anchor roller single stainless steel fitting	■	-	-
	Anchor roller double stainless steel fitting	PREMIERE	■	■
	Anchoring kit Delta anchor 20kg with 32 meters of 10mm chain and 45 meters of 18mm line	□	□	□
	Lifelines double level of stainless steel lifelines, stainless steel stanchions	■	■	■
	Lifeline gates opening gates on each side	PREFERENCE	PREFERENCE	PREFERENCE
	Toerail wood profile and drainage for side deck	■	-	-
	Toerail wood profile with 6 integrated stainless steel chocks and drainage for side deck	-	■	■
	Wood rubrail for hull protection	□	□	□
	Cleats 4 x stainless steel mooring cleats forward and aft	■	-	-
	Cleats 4 x aluminium mooring cleats forward and aft	-	■	■
	Midship cleats 2 x stainless steel cleats placed on side deck	PREMIERE	-	-
	Midship cleats 2 x aluminium cleats placed on side deck near midship chocks	-	PREMIERE	PREMIERE
	Mooring kit 6 fenders and 4 docklines	□	□	□
	Handrails sculpted, long wood handrails on coachroof for secure movement forward	■	■	■

		SO 409	SO 42i	SO 42i Performance
Construction	Deck Prisma Process® injected deck, ISO gelcoat surface, discontinuous balsa block coring	■	■	■
	Hull solid, hand-laid fibreglass, ISO gelcoat surface, protective barrier coat	■	■	■
	Structure 3 rd generation inner fibreglass grid, high-load zones cut out and relaminated, drainage system through structure, special emergency repair zone in keel area	■	■	■
Lighting	LED navigation lights and anchor light	PREMIERE	PREMIERE	PREMIERE
	Flush mounted LED chromed brass ceiling lights in saloon, head compartments and cabins	■	■	■
	Leather-wrapped LED reading lights in forward cabin and aft cabin (s)	■	-	-
	Indirect halogen lighting under side decks in saloon and head compartments	■	■	■
	Indirect LED lighting under furniture in saloon	PREFERENCE	-	-
	Gooseneck chart light mounted at nav station	■	■	■
Electrical	12 v alternator output	80 A	80 A	80 A
	Charge distributor/isolator	■	■	■
	Engine start battery capacity, batteries located under aft berths	110 Ah	110 Ah	110 Ah
	Domestic battery bank capacity, batteries located under aft berths	220 Ah	220 Ah	220 Ah
	Extra 110 Ah domestic battery	2x PREMIERE	1x PREMIERE	1x PREMIERE
	Positive battery switch for engine and domestic bank and general cut-off switch mounted on panel in aft cabin	■	■	■
	Shorepower 230v inlet with differential breaker, one 230v plug per cabin, 230v plug in galley, saloon and nav station	PREMIERE	■	■
	60A battery charger, multi-phase	PREMIERE	-	-
	40A battery charger, multi-phase	-	PREMIERE	PREMIERE
	Electrical panel with 12v breakers, 230v breakers, 12v ammeter, 12v consumption meter, 12v charging meter	■	■	■
	Solar panels on coachroof 2 x 45W with charging relay	□	-	-
	12v plug per cabin and at nav station	■	■	■
	230v stainless steel microwave, installed in galley cabinet	□	□	□
Plumbing	Hot and cold pressurised water distributed through-out the boat via semi-rigid hose	■	■	■
	"Heavy-duty" water pump and accumulator tank for consistent water pressure	■	■	■
	40 litre hot water tank that is connected to engine heat exchanger and to 230v electrical system	■	■	■
	Chromed shower faucets in washrooms	■	■	■
	Electric bilge pump on float switch and manual dual-action pump in the cockpit	■	■	■
	Digital water level display	■	■	■
	Shower sumps equipped with individual electric pumps with filters and on-off switches	■	■	■
	Large manual pump marine toilets	■	■	■
	Electric Quiet-Flush toilets in place of standard, available for each head compartment	□	-	-
	80 litre holding tank with gravity drain and deck fitting for forward starboard head (port aft head equipped with standard 85L tank)	□	-	-
	50 litre holding tank with gravity drain and deck fitting for forward starboard head (port aft head equipped with standard 85L tank)	-	□	□
Engine and Steering	Yanmar 3JH5-CE 40 HP , 29.4Kw Sail Drive latest generation of environmentally friendly engines	■	-	-
	Yanmar 4JH4E 54 HP , 39.6Kw latest generation of environmentally friendly engines	-	■	■
	Fully soundproofed engine compartment with engine access behind stairwell and from aft cabin	■	■	■
	Stainless steel propeller shaft 30mm diameter	-	■	■
	Fuel/water separator	■	■	■
	Built-in muffler, forced air ventilation and stainless steel exhaust fitting aft	■	■	■
	Fixed 3-blade propeller	■	■	-
	Folding propeller, 3-blade, Flex-o-Fold	✗	-	-
	Feathering propeller, 3-blade, Max-Prop	-	-	■
	Bow thruster installed in a tunnel with dedicated battery	□	□	□
	Fibreglass rudder	■	■	■
Line cutting collar on shaft for extra protection against fouling	-	□	□	

Comfort features and options	Fixed hull ports with track-mounted curtains and shades	8	4	4
	Opening cockpit and roof ports	2	4	4
	Lateral fixed windows	6	6	6
	Opening ports integrated into lateral windows	2	-	-
	Opening deck hatches	6	7	7
	Combination shade/insect screens for deck hatches	PREMIERE	■	■
	CD/radio/MP3 player in saloon	PREFERENCE	PREMIERE	PREMIERE
	Saloon stereo speakers x 2	PREFERENCE	■	■
	Cockpit speakers x 2, watertight	PREFERENCE	PREMIERE	PREMIERE
	TV LCD 20" mounted on an articulating arm on main saloon bulkhead to port of the forward cabin doorway and DVD player	□	-	-
	Amplified antenna for TV for masthead mounting	□	-	-
	Air Conditioning 230v 24000 BTU 2 units installed under saloon seating and in stern, vents in saloon and forward and aft cabins control panel and thermostat	□	□	□
	Forced air heating 1 unit 5500 BTU Webasto® diesel heater installed in stern, vents in aft cabin, saloon and head compartments	□	□	□

✗ Performance plus package * Navigation package ■ Standard □ Option - Not available

		SO 409			SO 42i	
		2C/1H	3C/1H	3C/2H	2C/2H	3C/2H
Wood	Fine Teak® interior laminated panels with solid wood trim around galley, companionway and cabinetry, finished in satin UV stabilised varnish	■	■	■	■	■
	Laminate floorboards with light-coloured lines, varnished edges	■	■	■	■	■
	Laminate floorboards in an oak finish, varnished edges	□	□	□	-	-
Forward cabin	Forward owner's cabin with central berth and storage forward of the berth	■	■	■	■	■
	Double berth, with wood trim, high-density foam mattress	2,10 x 2,00 m	2,10 x 2,00 m	2,10 x 2,00 m	2,05 x 1,85 m	2,05 x 1,85 m
	Deep cabinet with shelves and hanging rod	2	2	1	1	1
	White vinyl lining on hull with lateral wood shelf	■	■	■	■	■
	Desk/vanity with leatherette lining and fold-up mirror, reading light and chair with backrest	□	□	-	-	-
	Private forward head compartment with sink, clothes hook, mirror, towel holder, toilet paper holder, cabinet above sink and electric drainage pump	-	-	■	■	■
	Aft owner's cabin with access to starboard and large berth	■	-	-	■	-
Aft cabin	Double berth with high-density foam mattress	2,00 m x 1,78 m	-	-	2,00 m x 1,75 m	-
	Deep cabinet with shelves and hanging rod	■	-	-	■	-
	White vinyl lining on hull with lateral wood shelf	■	-	-	■	-
	Large head compartment aft with sink, clothes hook, mirror, towel holder, toilet paper holder, cabinet above sink and electric drainage pump	■	-	-	■	-
	Plexiglass folding door for separate shower compartment	PREMIERE	-	-	■	-
	Locker and technical compartment with access through head compartment, storage baskets, lighting and lots of extra space for storage under the exterior cockpit locker	■	-	-	■	-
	Twin aft cabins	-	■	■	-	■
	Double berths, high-density foam	-	2,00 m x 1,57 m	2,00 m x 1,57 m	-	2,00 m x 1,48 m
	Deep cabinet with shelves and hanging rod per cabin	-	■	■	-	■
	White vinyl lining on hull with lateral wood shelf	-	■	■	-	■
	Head compartment aft with sink, separate shower, clothes hook, mirror, towel holder, toilet paper holder, cabinet above sink, electric drainage pump, access from saloon	-	■	■	-	-
	Plexiglass folding door for separate shower compartment	-	PREMIERE	PREMIERE	-	-
	Head compartment aft with sink, shower, clothes hook, mirror, towel holder, toilet paper holder, cabinet above sink, shower sump with grate and electric drainage pump, access from saloon	-	-	-	-	■
Navigation station	Navigation station full-function with general electrical panel, room for the latest in GPS chartplotters and bookshelf	■	■	■	■	■
	Sliding nav desk that can be placed in forward-facing or aft-facing position for increased seating with curved nav seat and storage underneath	-	-	-	■	■
	Saloon with U-shaped seating area to starboard, wrap-around cushions and storage under seating area	■	■	■	■	■
Saloon	Saloon dining table with wood fiddles, removable pedestal legs	■	■	■	■	■
	Luxury salon table with central bar unit, folding top, and sliding tracks to transform into double berth	PREFERENCE	PREFERENCE	PREFERENCE	-	-
	Saloon table with two fold-down leaves, bottle storage and conversion kit for double berth	-	-	-	PREMIERE	PREMIERE
	2 stools in saloon	□	□	□	-	-
	Storage cabinets along hull sides	■	■	■	■	■
	Lounge seating to port with plush cushions and upper storage cabinets	■	■	■	■	■
	Companionway with wood steps and non-slip strips	■	■	■	■	■
	Plexiglass companionway door with dedicated storage location	■	■	■	■	■
Galley	Galley with double stainless steel sinks with covers, and reversible cutting board, solid countertops, chrome plumbing fittings, storage cabinets and drawers	■	■	■	■	■
	L-galley to port with glass separator between galley counter and seating area	■	■	■	■	■
	Leatherette lined storage compartment for books and magazines built into the galley façade	■	■	■	-	-
	Gimballed 2-burner stove with oven with stainless steel protection bar	■	■	■	■	■
	Luxury 2-burner stove with black finish, wood handle, stainless steel oven/broiler	PREMIERE	PREMIERE	PREMIERE	PREMIERE	PREMIERE
Single fridge box with freezer area, wire baskets, 12v refrigeration and integrated compressor	■	■	■	■	■	
Headroom	Forward cabin		1,84 m		1,90 m	
	Aft cabin (s)		1,95 m		1,96 m	
	Companionway		1,94 m		1,99 m	
	Saloon		1,92 m		1,97 m	
	Galley		1,91 m		1,95 m	

■ Standard □ Option - Not available C = Cabins H = Head



JEANNEAU